



US005860973A

United States Patent [19]

[11] Patent Number: **5,860,973**

Michelson

[45] Date of Patent: **Jan. 19, 1999**

[54] **TRANSLATERAL SPINAL IMPLANT**

[76] Inventor: **Gary Karlin Michelson**, 438 Sherman Canal, Venice, Calif. 90291

[21] Appl. No.: **741,301**

[22] Filed: **Oct. 30, 1996**

Related U.S. Application Data

[63] Continuation of Ser. No. 479,596, Jun. 7, 1995, abandoned, which is a continuation-in-part of Ser. No. 394,836, Feb. 27, 1995.

[51] **Int. Cl.⁶** **A61B 17/56**

[52] **U.S. Cl.** **606/61; 606/72**

[58] **Field of Search** **606/61, 72-78, 606/86, 87, 88; 623/16, 17**

4,904,261	2/1990	Dove et al. .	
4,911,718	3/1990	Lee	623/17
4,936,848	6/1990	Bagby .	
4,955,908	9/1990	Frey et al. .	
4,961,740	10/1990	Ray et al. .	
5,015,247	5/1991	Michelson .	
5,015,255	5/1991	Kuslich .	
5,026,373	6/1991	Ray et al. .	
5,055,104	10/1991	Ray .	
5,059,193	10/1991	Kuslich .	
5,071,437	12/1991	Steffee .	
5,123,926	6/1992	Pisharodi .	
5,192,327	3/1993	Brantigan .	
5,258,031	11/1993	Salib et al. .	
5,263,953	11/1993	Bagby .	
5,306,309	4/1994	Wagner et al. .	
5,397,364	3/1995	Kozak et al. .	
5,425,772	6/1995	Brantigan .	
5,489,308	2/1996	Kuslich et al. .	

FOREIGN PATENT DOCUMENTS

0 260 044	3/1988	European Pat. Off. .
0 179 695	4/1986	France .

Primary Examiner—Michael Buiz
Assistant Examiner—Kevin Truong
Attorney, Agent, or Firm—Lewis Anten, Esq.; Amedeo Ferraro, Esq.

[57] **ABSTRACT**

An oversized spinal implant for translateral insertion into the disc space between two vertebrae a length that is greater than one half of the transverse width of the vertebrae and is greater than the depth of the vertebrae. The translateral implant of the present invention has a height that is greater than the height of the disc space between two adjacent vertebrae so as to engage both of the vertebrae. The width of the implant need be only slightly less than the depth of the vertebrae themselves. The translateral spinal fusion implant of the present invention has more surface area of contact and thus permits greater stability so as to withstand torque, and in the case of a threaded implant, increases the depth which any threads are able to penetrate the vertebrae.

73 Claims, 8 Drawing Sheets

[56] **References Cited**

U.S. PATENT DOCUMENTS

2,677,369	5/1954	Knowles .	
3,298,372	1/1967	Feinberg .	
3,867,728	2/1975	Stubstad et al. .	
3,875,595	4/1975	Froning .	
3,905,047	9/1975	Long .	
4,070,514	1/1978	Entherly et al. .	
4,259,072	3/1981	Hirabayashi et al. .	
4,309,777	1/1982	Patil .	
4,328,593	5/1982	Sutter	623/18
4,349,921	9/1982	Kuntz	623/17
4,501,269	2/1985	Bagby	623/18
4,535,485	8/1985	Ashman et al. .	
4,545,374	10/1985	Jacobson .	
4,553,273	11/1985	Wu .	
4,599,086	7/1986	Doty .	
4,636,217	1/1987	Ogilvie et al. .	
4,714,469	12/1987	Kenna .	
4,759,766	7/1988	Buettner-Janz et al. .	
4,759,769	7/1988	Hedman et al. .	
4,820,305	4/1989	Harms et al. .	
4,848,327	7/1989	Perdue .	
4,863,477	9/1989	Monson .	
4,865,603	9/1989	Noiles .	
4,877,020	10/1989	Vich .	

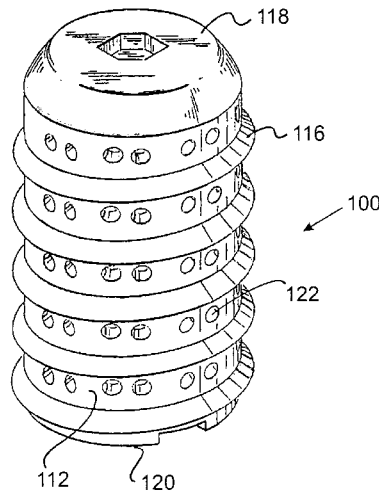

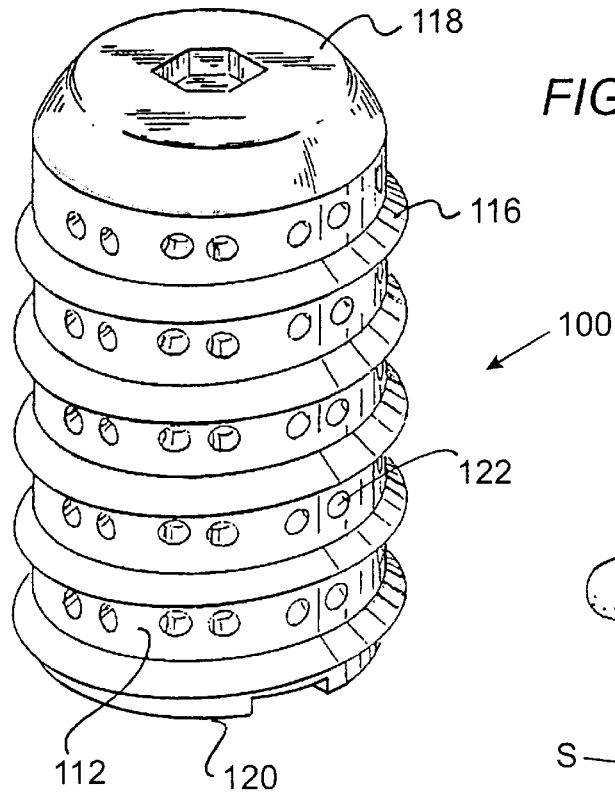

FIG. 1

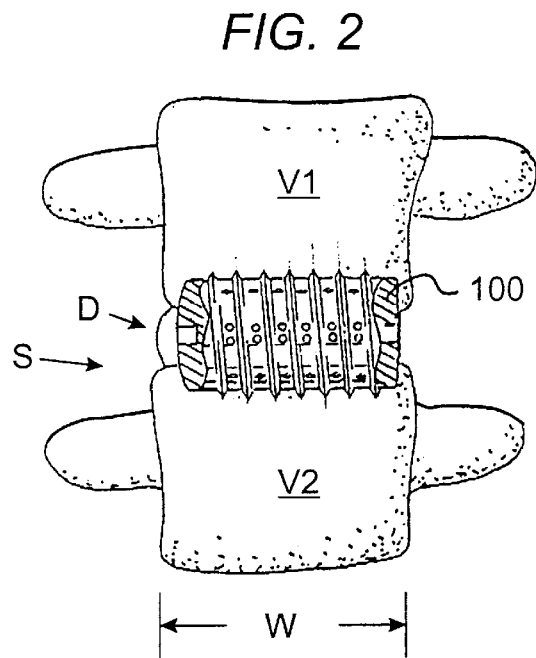

FIG. 2

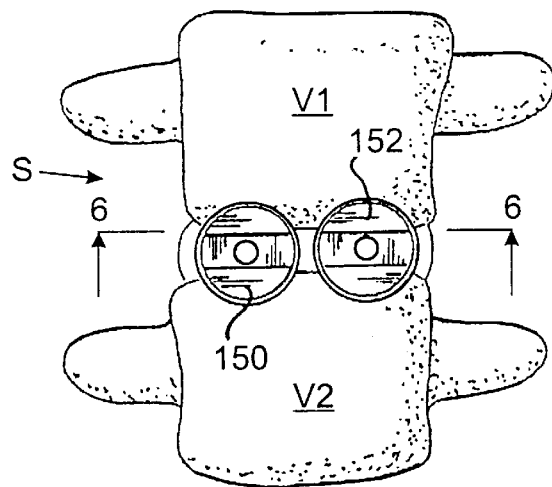

FIG. 5

FIG. 3

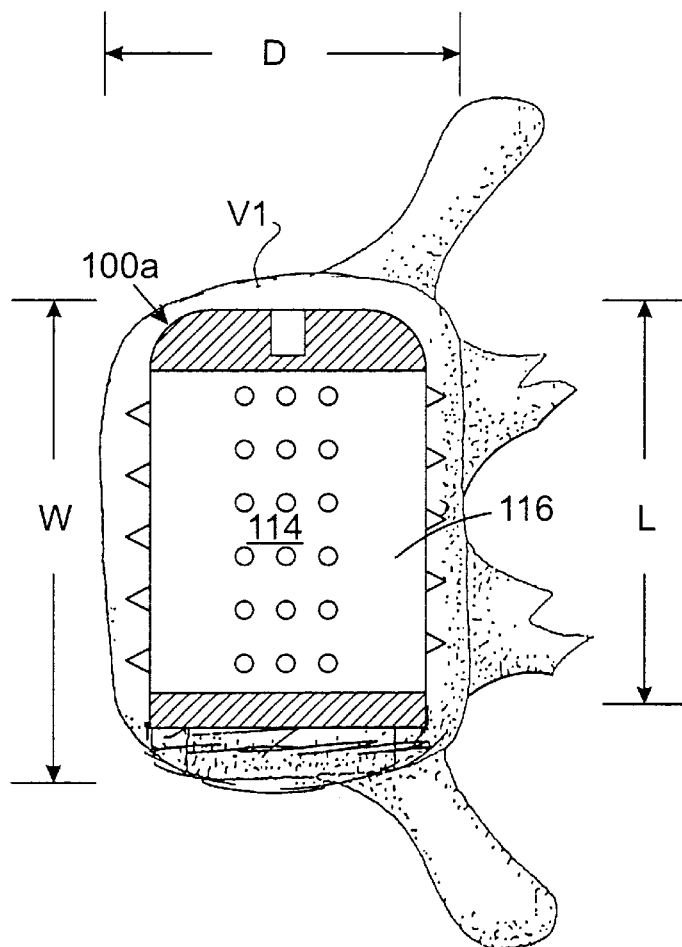
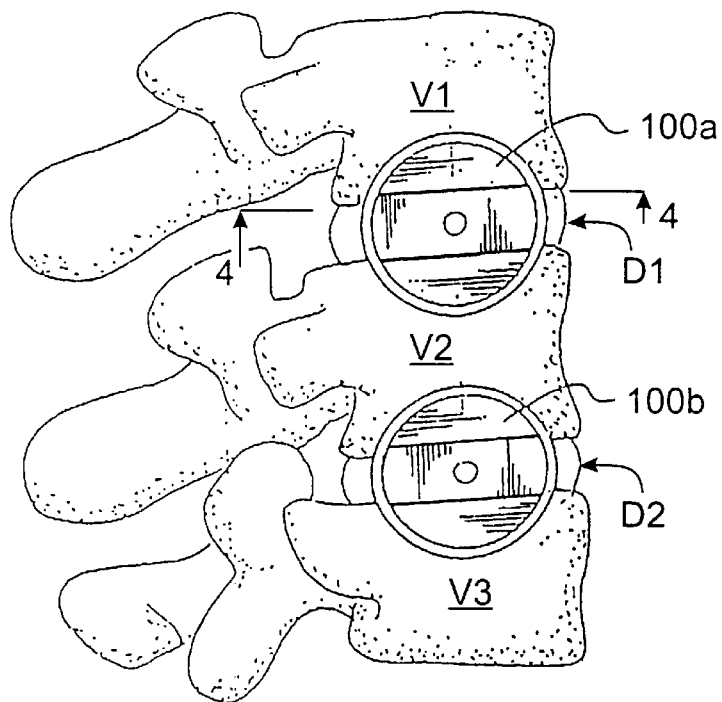

FIG. 4

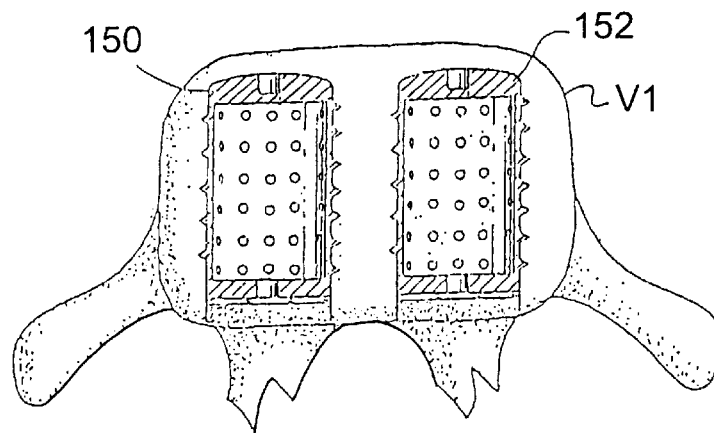

FIG. 6

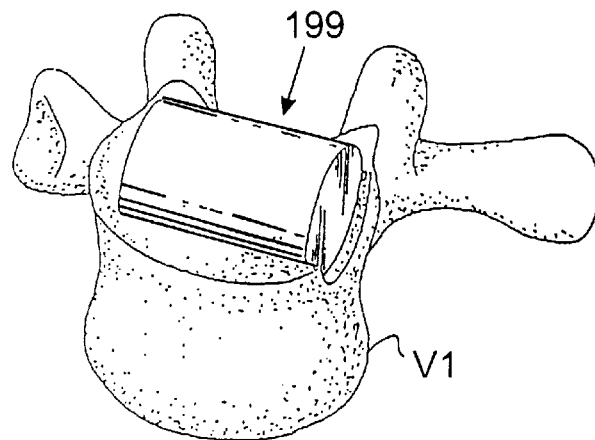

FIG. 7

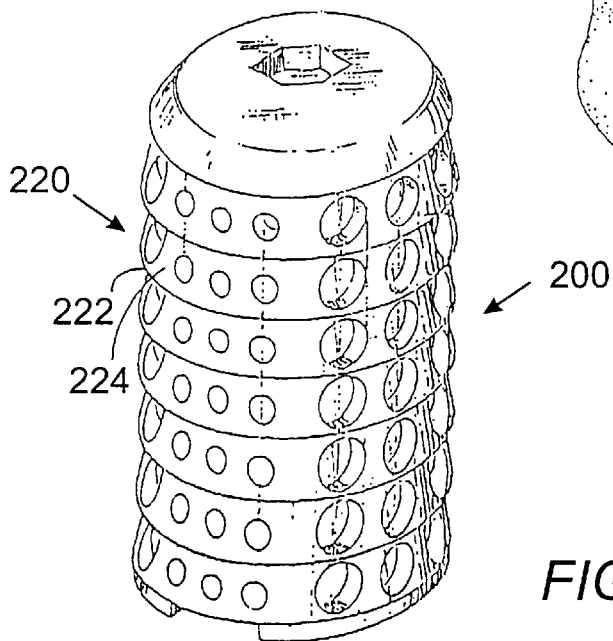

FIG. 8

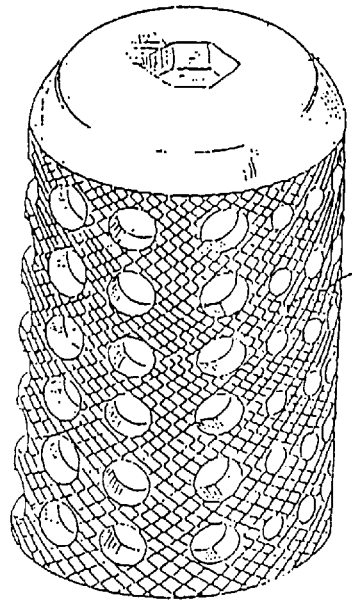

FIG. 9

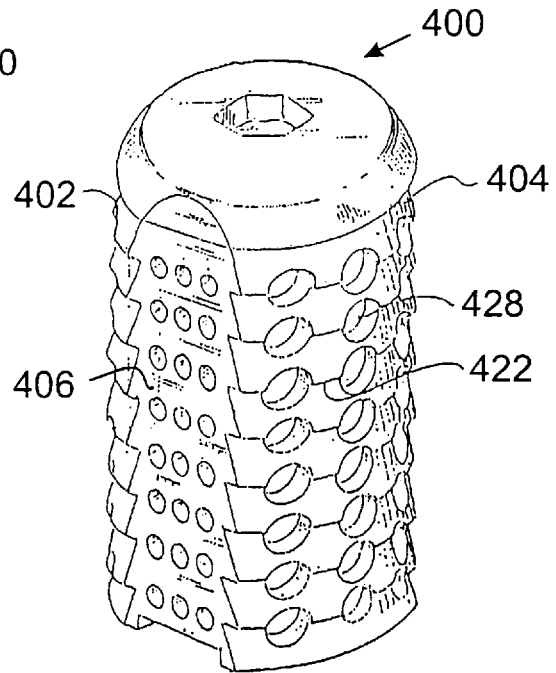

FIG. 10

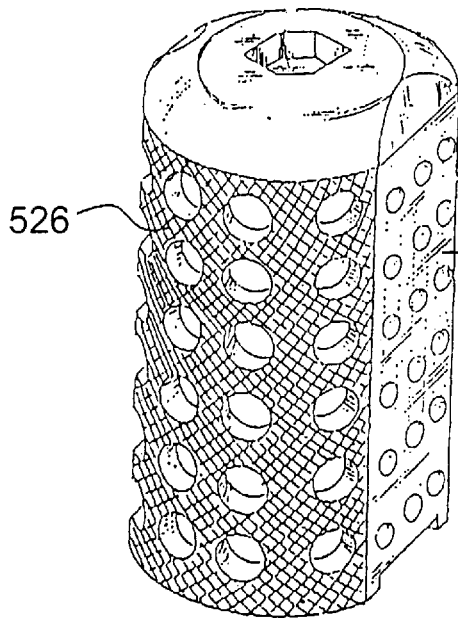

FIG. 11

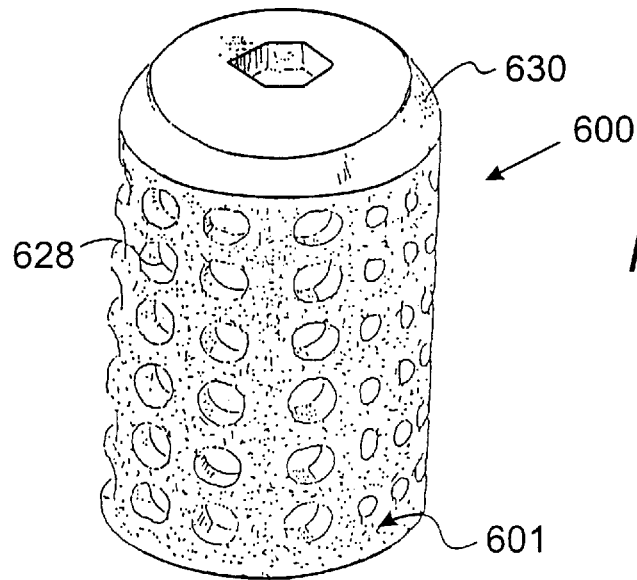

FIG. 12

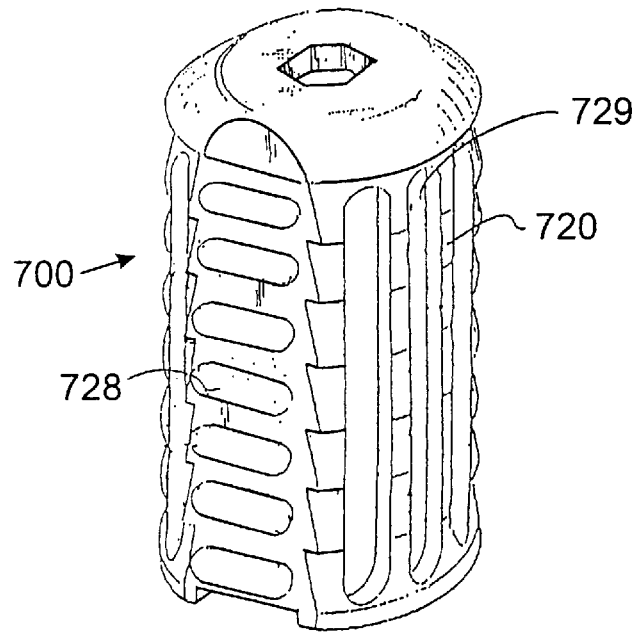

FIG. 13

FIG. 15

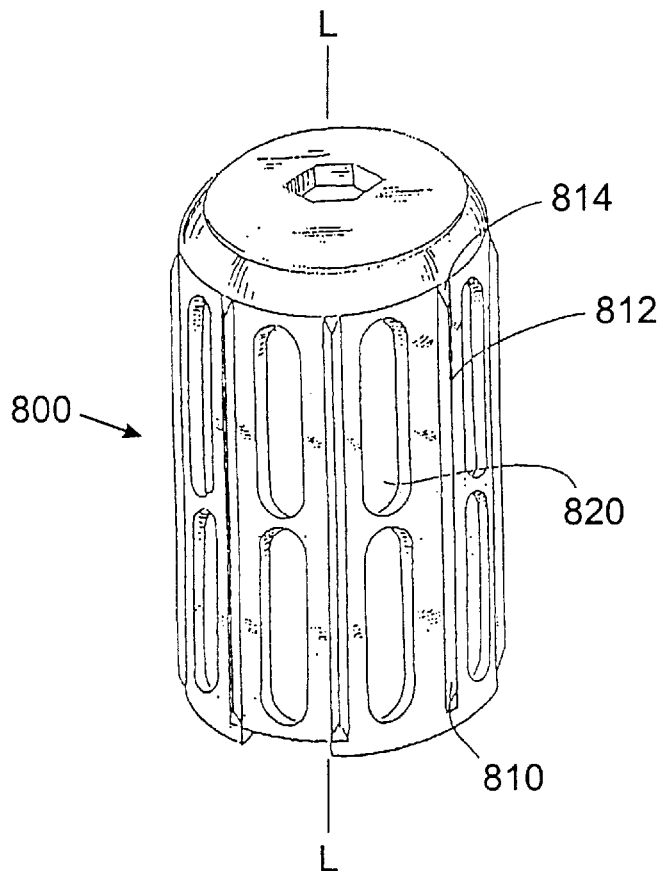
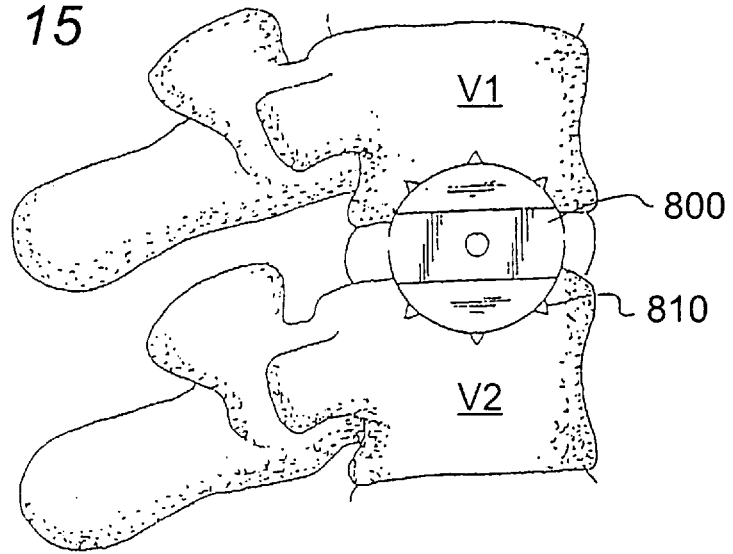

FIG. 15b

FIG. 18

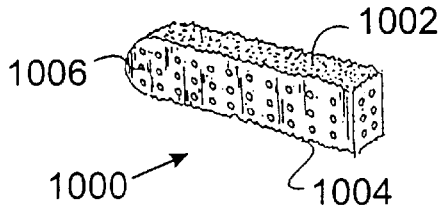

FIG. 16

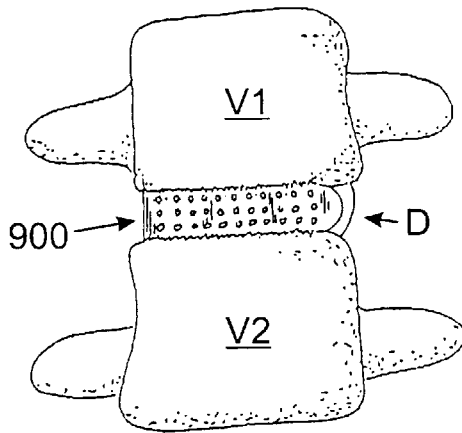
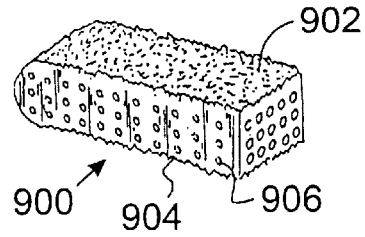
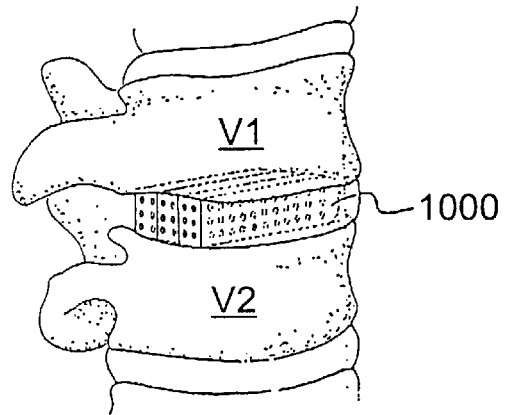

FIG. 17

FIG. 19



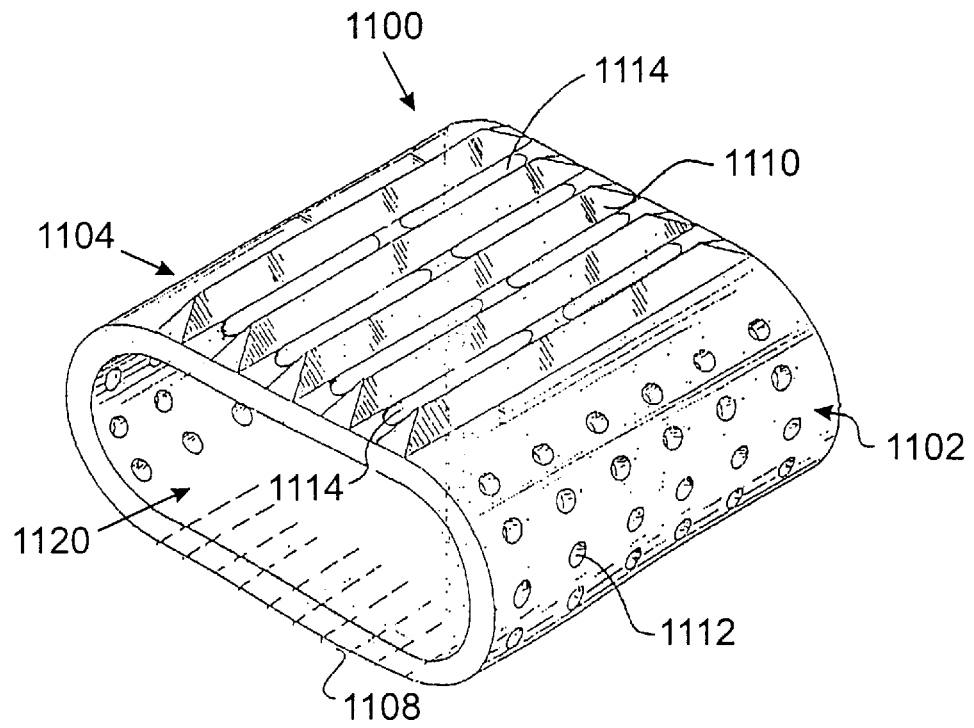

FIG. 20

TRANSLATERAL SPINAL IMPLANT

RELATED APPLICATIONS

This is a continuation of the application Ser. No 08/479, 596 filed on Jun. 7, 1995, now abandoned, which is a continuation in part of application Ser. No. 08/394,836 entitled IMPROVED METHODS AND INSTRUMENTATION FOR THE SURGICAL CORRECTION OF HUMAN THORACIC AND LUMBAR SPINAL DISEASE FROM THE LATERAL ASPECT OF THE SPINE, filed on Feb. 27, 1995 now pending, incorporated herein by reference.

BACKGROUND OF THE INVENTION

1. Field of the Invention

This invention relates generally to spinal fusion implants, and more particularly to spinal fusion implants for insertion from the side of a patient (translateral) across the transverse width of the spine and between two adjacent vertebrae.

2. Description of the Related Art

In the past, spinal fusion implants have been inserted only from either an anterior or posterior direction, from the front or the back of the patient. Such implants are well known in the art and may have cylindrical, rectangular and other shapes. In the past, Cloward, Wilterberger, Crock, Viche, Bagby, Brantigan, and others have taught various methods involving the drilling of holes across the disc space between two adjacent vertebrae of the spine for the purpose of causing an interbody spinal fusion. Cloward taught placing a dowel of bone within that drilled hole for the purpose of bridging the defect and to be incorporated into the fusion. Viche taught the threading of that bone dowel. Bagby taught the placing of the bone graft into a metal bucket otherwise smooth on its surface, except for rows of radially placed holes communicative to the interior of the basket and to the bone graft. The Bagby device was disclosed as capable of being used in a horse. Brantigan taught the use of inert blocks preferably made of metal and having that metal at its external surface imitate the porosity of bone. Brantigan theorized that the bone dowel could be replaced entirely with a metal plug that, while not itself active in the fusion, would nevertheless serve to support the vertebrae from within the disc space while allowing fusion to occur around it.

U.S. Pat. No. 3,844,601 issued to Ma et al. on Nov. 19, 1974, teaches a method and instrumentation for preparing rectangular spaces across the disc space into the adjacent vertebrae and for preparing a rectangular graft of the bone itself that is inserted in the rectangular spaces.

U.S. Pat. No. 4,743,256 issued to Brantigan on May 10, 1988 teaches the use of an inert artificial spacer in the shape of a rectangle in place of using a rectangular bone graft as taught by Ma et al.

U.S. Pat. No. 4,878,915 issued to Brantigan on Nov. 7, 1989, teaches the use of fully cylindrical inert implants for use in interbody spinal fusion. Such implants do not participate in the bone fusion process but act as inert spacers and allow for the growth of bone to the outer surfaces of the implants.

U.S. Pat. No. 4,834,757 issued to Brantigan on May 30, 1989, teaches a rectangular shaped, hollow spinal fusion implant for use in lieu of a rectangular bone graft or Brantigan's earlier artificial inert spacer.

However, all of the prior implants have been inserted from either the front or the back of the patient. As a result, the spinal fusion implants of the past were necessarily limited in

size to the dimensions of the vertebrae relative to the direction in which the implants were inserted. For example, the maximum possible length for an implant that is inserted from either the front or the back of the patient is limited to the depth of the vertebrae, the depth of a vertebrae being the dimension of the vertebrae measured from the anterior end to the posterior end of the vertebrae. It was not previously possible to insert an implant that had a length that was greater than the depth of the vertebrae from front to back as such an implant would protrude from either the anterior or posterior aspect of the spine resulting in great harm to the patient.

In U.S. Pat. No. 5,015,247 to Michelson, a cylindrical threaded implant is described for insertion across the disc space between two adjacent vertebrae. Such an implant was disclosed as being inserted either from the front of the patient or from the back and has a diameter larger than the disc space so that it engages both of the adjacent vertebrae.

The maximum diameter possible with a cylindrical implant that is inserted from the front or the back of the patient is limited by at least two factors. The first factor limiting the diameter of a cylindrical implant is realized when an attempt is made to use a single, centrally placed implant from either the front or the back of the patient. Such an implant must be large enough to occupy a sufficient portion of the transverse width of the disc space to promote firm stability. The use of an implant that is placed in the disc space to stabilize the two adjacent vertebrae requires that the vertebrae be stable when the implant is in place, otherwise there will not be any bone bridging between the implant and the vertebrae. If a single implant is used in the center of the disc space, inherent instability is created, as the vertebrae are generally free to rock back and forth over the implant which serves as a fulcrum. However, to achieve the required stability, it would be necessary to use the widest possible implant and the excursion of such a large single implant into the adjacent vertebrae would be so severe that the two vertebrae would be virtually cut in half.

The second factor which limits the diameter size of a cylindrical implant is in the situation where two cylindrical implants are implanted from either the front or the back of the patient and placed side-by-side across a disc space and into the two adjacent vertebrae in an attempt to gain stability while avoiding the problems of the single implant. Such implants require a diameter that is sufficiently large to penetrate into and significantly engage each of the adjacent vertebrae yet the diameter may not be so large that it is no longer possible to place two such implants side-by-side and to still have them contained within the transverse width of the spine.

The use of multiple implants requires that the implants be small enough so as to fit into the same limited spinal width. These implants being of smaller diameter as limited by the need to place more than one within the width of the spine then penetrate only minimally into the depth of the vertebral bone.

Also, the insertion of multiple implants requires multiple procedures, essentially a duplication of any procedure done on one side of the center line must also be performed on the other side of the center line.

Therefore, there exists a need for a spinal fusion implant that is inserted from the translateral approach to the spine that is capable of stabilizing the vertebrae adjacent to such an implant in order to permit bone bridging between the vertebrae and the implant to ultimately achieve fusion of the adjacent vertebrae.

SUMMARY OF THE INVENTION

The present invention discloses a spinal fusion implant that is inserted from the side of the patient, herein referred to as the translateral approach to the spine. The translateral spinal fusion implant of the present invention is inserted into the spine of a patient across the transverse width of the vertebrae to be fused. The transverse width of a vertebra is measured from one lateral aspect of the spine to the opposite lateral aspect. The depth of a vertebra is measured from the anterior aspect to the posterior aspect of the spine.

As the translateral spinal fusion implant of the present invention is inserted substantially along the transverse width of the vertebrae or at a slight angle to the vertebrae, it has a different structural configuration as compared to spinal implants for insertion from either the front or the back of the patient, as such implants are necessarily limited by the depth, measured from front to back of the vertebrae.

In one embodiment of the translateral spinal fusion implant of the present invention, the implant is dimensioned to fit within a bore created across the disc space and into the adjacent vertebrae. Such an implant may be substantially cylindrical and has an outer surface comprising bone engaging means for engaging the implant to the adjacent vertebrae. In this embodiment, for the lumbar spine, the translateral spinal fusion implant of the present invention has a length that is greater than one half of the transverse width of the vertebrae and is greater than the depth of the vertebrae. The translateral implant of the present invention has a height that is greater than the height of the disc space between two adjacent vertebrae so as to engage both of the vertebrae. The width of the implant need be only slightly less than the depth of the vertebrae themselves.

In another embodiment of the present invention, the translateral spinal fusion implant of the present invention is dimensioned to fit within the disc space created by the removal of disc material between two adjacent vertebrae. Such an implant is inserted from the translateral approach to the spine and has a length that is substantially greater than the depth of the vertebrae and a width that approximates the depth of the vertebrae. The height of such an implant is approximately the same height of the normal height of the disc space between two adjacent vertebrae and may be wedged so as to reproduce anatomic lordosis. The upper and lower surfaces of such an implant may be contoured so as to conform to the shape of the disc space and the adjacent vertebral endplate surfaces.

The dimensions of the translateral spinal fusion implant of the present invention permits a single implant to be inserted by a single procedure into the spine and to engage more of the adjacent vertebrae. As a result, the translateral spinal fusion implant of the present invention has more surface area of contact and thus permits greater stability so as to withstand torque, and in the case of a threaded implant, increases the depth which any threads are able to penetrate the vertebrae.

The translateral implants of the present invention are safer to use than implants inserted from the front or the back as the aorta and vena cava lie anterior to the spine and the dural sac and nerves posteriorly, all of which structures are simply avoided in the lateral approach.

The translateral spinal fusion implant of the present invention may be inserted into the disc space through a hollow tube which is engaged to the lateral aspect of the spine through a lateral, anterior, or anterolateral incision making the procedure safe and simple.

The translateral spinal fusion implant of the present invention may comprise at least in part fusion promoting

and/or bioactive materials for active participation of the implant in the spinal fusion process.

OBJECTS OF THE PRESENT INVENTION

It is an object of the present invention to provide a spinal fusion implant that may be inserted from a translateral approach to the spine.

It is another object of the present invention to provide a spinal fusion implant that is safer to use than the implants of the past.

It is another object of the present invention to provide a spinal fusion implant that is easier to insert into the spine.

It is a further object of the present invention to provide a spinal fusion implant that provides greater stability of the vertebrae being fused.

It is yet another object of the present invention to provide a spinal fusion implant that is less likely to fail.

It is another object of the present invention to provide a spinal fusion implant that is more deeply embedded into the adjacent vertebrae.

These and other objects of the present invention will become apparent from a review of the accompanying drawings and the detailed description of the drawings.

BRIEF DESCRIPTION OF THE DRAWINGS

FIG. 1 is a perspective side view of the translateral spinal fusion implant of the present invention having an external thread for engaging the bone of two adjacent vertebrae.

FIG. 2 is an elevational view of the anterior aspect of a segment of the spinal column with the spinal fusion implant of FIG. 1 inserted from the lateral aspect along the transverse width of the vertebrae.

FIG. 3 is an elevational view of the lateral aspect of a segment of the lumbar spine with a first spinal fusion implant of the present invention inserted from the lateral aspect into a hole drilled across a first disc space and into two adjacent vertebrae, and a second spinal fusion implant of the present invention inserted from the lateral aspect into a second hole drilled across a second disc space and into two adjacent vertebrae.

FIG. 4 is top sectional view along lines 4—4 of FIG. 3 showing the area of contact of the spinal fusion implant of the present invention and the vertebra.

FIG. 5 is an anterior elevational view of a segment of the lumbar spine with two cylindrical implants inserted from the anterior of the spine into holes drilled across the same disc space and into two adjacent vertebrae.

FIG. 6 is sectional view along lines 6—6 of FIG. 5 showing the area of contact between the two implants of FIG. 5 and the vertebra.

FIG. 7 is a anterior perspective view of a single vertebra and an alternative embodiment of the spinal fusion implant of the present invention in the form of a dowel inserted translationally into a hole drilled across a disc space and into the vertebra along the transverse width of the vertebra.

FIG. 8 is a perspective view of an alternative embodiment of the spinal fusion implant of the present invention having ratchetings for engaging the vertebrae.

FIG. 9 is a perspective view of an alternative embodiment of the spinal fusion implant of the present invention having a knurled surface for engaging the vertebrae.

FIG. 10 is a perspective view of an alternative embodiment of the spinal fusion implant of the present invention having ratchetings for engaging the vertebrae and a flattened side.

FIG. 11 is a perspective view of an alternative embodiment of the spinal fusion implant of the present invention having a knurled surface for engaging the vertebrae and a flattened side.

FIG. 12 is a perspective view of an alternative embodiment of the spinal fusion implant of the present invention having a blasted surface for engaging the vertebrae.

FIG. 13 is a perspective view of an alternative embodiment of the spinal fusion implant of the present invention having ratchetings for engaging the vertebrae with openings in the form of vertical and horizontal slots.

FIG. 14 is a perspective view of an alternative embodiment of the spinal fusion implant of the present invention having longitudinal splines for engaging the vertebrae and openings in the form of vertical slots.

FIG. 15 is elevational view of the lateral aspect of the spinal column having the spinal fusion implant of FIG. 14 inserted from the lateral aspect along the transverse width of the vertebrae into a hole created across the disc space and into two adjacent vertebrae.

FIG. 16 is a perspective side view of an alternative embodiment of the spinal fusion implant of the present invention.

FIG. 17 is a elevational anterior view of a segment of the spinal column having the spinal fusion implant of FIG. 16 inserted from the lateral aspect in the disc space between two adjacent vertebrae along the transverse width of the vertebrae.

FIG. 18 is a perspective side view of an alternative embodiment of the spinal fusion implant of the present invention.

FIG. 19 is a perspective lateral anterior view of a segment of the spinal column with a plurality of the spinal implants of FIG. 18 shown in hidden line inserted from the lateral aspect in a modular fashion in the disc space between two adjacent vertebrae along the transverse width of the vertebrae.

FIG. 20 is perspective view of an alternative embodiment of the spinal fusion implant of the present invention.

DETAILED DESCRIPTION OF THE DRAWINGS

Referring to FIGS. 1–5, an embodiment of the translateral spinal fusion implant of the present invention, generally referred to by numeral 100, is shown. The spinal fusion implant 100 has a substantially cylindrical configuration having an outer wall 112 surrounding an internal chamber 114 for holding fusion promoting material. The exterior of the spinal fusion implant 100 comprises an external thread 116 suitable for engaging the vertebrae of the spine to stabilize the spinal fusion implant 100 across the disc space and into adjacent vertebrae once surgically implanted. The spinal fusion implant 100 has a removable cap 118 at one end which provides access to the internal chamber 114 and has an insertion end 120 adapted to engage insertion instrumentation.

The cap 118 is removable to provide access to the internal chamber 114, such that the internal chamber 114 can be filled and hold any natural or artificial osteoconductive, osteoinductive, osteogenic, or other fusion enhancing material. Some examples of such materials are bone harvested from the patient, or bone growth inducing material such as, but not limited to, hydroxyapatite, hydroxyapatite tricalcium phosphate; or bone morphogenic protein. The cap 118 and/or the spinal fusion implant 100 itself is made of material appropriate for human implantation such as titanium and/or

may be made of, and/or filled and/or coated with a bone ingrowth inducing material such as, but not limited to, hydroxyapatite or hydroxyapatite tricalcium phosphate or any other osteoconductive, osteoinductive, osteogenic, or other fusion enhancing material.

The outer wall 112 comprises openings 122 which may be closed wells or openings communicating into the internal chamber 114 to permit bone ingrowth into the chamber 114.

Referring specifically to FIG. 2, an elevational view of the anterior aspect of a segment of the spinal column S with the spinal fusion implant 100 inserted from the lateral aspect of the spinal column S into a hole bored into the adjacent vertebrae V_1 and V_2 across the disc space D. The spinal fusion implant 100 is inserted along the transverse width W of the adjacent vertebrae V_1 and V_2 such that the spinal fusion implant 100 extends translaterally in the direction from one lateral aspect of the vertebrae to the opposite lateral aspect of the vertebrae.

Referring to FIG. 3, an elevational view of the lateral aspect of a segment of the lumbar spine S is shown with a first implant 100a, identical to spinal fusion implant 100, inserted from the lateral aspect into a hole bored across a first disc space D_1 and into two adjacent vertebrae V_1 and V_2 , and a second implant 100b, identical to spinal fusion implant 100, inserted from the lateral aspect into a second hole bored across a second disc space D_2 and into two adjacent vertebrae V_2 and V_3 .

The translateral implants of the present invention are inserted by the translateral method disclosed in copending application Ser. No. 08/394,836 entitled IMPROVED METHODS AND INSTRUMENTATION FOR THE SURGICAL CORRECTION OF HUMAN THORACIC AND LUMBAR SPINAL DISEASE FROM THE LATERAL ASPECT OF THE SPINE, filed on Feb. 27, 1995, which is incorporated herein by reference. The translateral implants of the present invention may be made of an artificial material.

Referring to FIG. 4, a top sectional view along lines 4–4 of FIG. 3 is shown illustrating the area of contact of the implant 100a and the vertebra V_1 . The vertebra V_1 has a depth D measured from the anterior to posterior aspect of the spine, and a transverse width W measured from one lateral aspect to the opposite lateral aspect of the vertebra V_1 . The implant 100a has a length L that is substantially greater than the depth D of the vertebra V_1 such that the implant 100a may extend substantially across the transverse width W of the vertebra V_1 . In the preferred embodiment, the implant 100a has a length L that is greater than one half the transverse width W of the vertebrae and has a diameter of a sufficiently large size that approximates the depth D of the vertebra V_1 . As a result of the large length and diameter of the implant 100a, a large surface area of contact between the implant 100a and the vertebrae V_1 is possible creating a highly stable construct. The implant 100a has a much greater surface area of contact with the vertebra V_1 than was previously possible with implants that are inserted from the front or the back of the spine.

As described above in the Background of the Invention, a centrally placed single implant from either the front or the back of the patient must be large enough to occupy a sufficient portion of the transverse width W of the vertebrae to promote firm stability. However, the vertical height of such an implant and excursion into the adjacent vertebrae would be so severe that if any two consecutive disc spaces were to be operated upon, the vertebra in between the disc spaces would be cut in half. Therefore it has been the practice to use multiple implants, one on each side of the

center line (mid-sagittal axis) of the vertebrae, thereby providing a greater degree of stability.

Referring to FIG. 5, an anterior elevational view of a segment of the lumbar spine S is shown with two cylindrical implants **150** and **152** inserted from the anterior aspect of the spine S into holes drilled across the same disc space D and into two adjacent vertebrae V_1 and V_2 .

Referring to FIG. 6, sectional view along lines 6—6 of FIG. 5 illustrating the area of contact between the two implants **150** and **152** inserted from the anterior aspect of the spine and the vertebra V_1 is shown. As can be seen from FIG. 6, the surface area of the two spinal implants **150** and **152** in contact with the vertebra V_1 is substantially less than that of a single translateral spinal fusion implant **100** that is inserted across the transverse width W of the vertebra V_1 . As a result, a more stable construct is achieved with the translateral spinal fusion implant **100** of the present invention than was previously possible with implants that are inserted from either the front or the back of the patient promoting from stability of the fusion construction.

In the preferred embodiment, the spinal fusion implant **100** of the present invention has an overall length in the range of 35 mm to 50 mm, with 38–44 mm being preferred, and a maximum diameter in the range of 22 mm to 30 mm, with 24–26 mm being preferred when inserted in the lumbar spine. In the thoracic spine such implants would have a length in the range of 12–30 mm, and a maximum diameter in the range of 14–26 mm, with the preferred diameter being 20 mm.

Referring to FIG. 7, an anterior perspective view of a single vertebra V_1 and an alternative embodiment of the translateral spinal fusion implant of the present invention, generally referred to by the numeral **199**, is shown. The spinal fusion implant **199** is a dowel inserted into a hole drilled across a disc space and into the vertebra V_1 along the transverse width of the vertebra V_1 . The spinal fusion implant **199** has the same dimensions as the spinal fusion implant **100** described above. The spinal fusion implant **199** can be made of any material suitable for human implantation may comprise fusion promoting and/or bioactive material to actively participate in the spinal fusion process. The implant **199** can be made of a porous, and/or mesh-like, and/or cancellous material, or any other material suitable for the described purpose.

Referring to FIG. 8, an alternative embodiment of the translateral spinal fusion implant of the present invention, is shown and generally referred to by the numeral **200**. The spinal fusion implant **200** has a substantially cylindrical configuration having a thin outer wall **212** surrounding an internal chamber **214**. The exterior of the spinal fusion implant **200** comprises surface roughenings that provide a surface suitable for engaging the bone of the vertebrae to stabilize the spinal fusion implant **200** across the disc space and into the adjacent vertebrae once surgically implanted. The surface roughenings comprise a plurality of ratchetings **220** along the circumference of the spinal fusion implant **200**. Each of the plurality of ratchetings **220** has a bone engaging edge **222** and an angled segment **224**.

The spinal fusion implant **200** is implanted into a cylindrical bore derived across the disc space and into two adjacent vertebrae. The spinal fusion implant **200** may be pushed into the cylindrical bore across the disc space by direct, linear advancement since it requires no thread to pull it forward through the spine. As no torque is required to advance the spinal fusion implant **200** there is no minimum requisite height of the surface roughenings.

The ratchetings **220** may face in one direction, the direction in which the spinal fusion implant **200** is inserted, and function to prevent the spinal fusion implant **200** from backing out of the disc space in a direction opposite to the direction of insertion once inserted between the two adjacent vertebrae. The ratchetings **220** urge the spinal fusion implant **200** forward against the unremoved bone of the vertebrae. Since implants generally want to back out along the same path in which they are inserted, the ratchetings **220** tend to urge the spinal fusion implant **200** forward against the solid unremoved bone at the end of the cylindrical bone, further resisting dislodgement and controlling motion resulting in an exceedingly stable implantation.

The spinal fusion implant **200** has an engagement means at one end for engaging a driver instrument for intimately engaging and binding the implant **200** and the driver instrument together. Once affixed to the implant driver instrument, the spinal fusion implant **200** may be then introduced through a hollow cylindrical tube and driven into the cylindrical hole that has been drilled across the disc space. The implant driver instrument may then be impacted by a mallet, or similar device, to linearly advance the spinal fusion implant **200** across the disc space. Once the spinal fusion implant **200** is inserted across the disc space, the ratchetings **220**, engage the bone of the vertebrae and the implant driver instrument is detached from the spinal fusion implant **200**.

Referring to FIG. 9, an alternative embodiment of the spinal fusion implant of the present invention generally referred to by the numeral **300** is shown. The spinal fusion implant **300** has a substantially cylindrical configuration having surface roughenings for stabilizing the implant **300** within the intervertebral space D. The surface roughenings comprise a surface knurling **320** such as, but not limited to, the diamond-shaped bone engaging pattern shown in FIG. 9. The spinal fusion implant **300** may have surface knurling **320** throughout the entire external surface of the spinal fusion implant **300**, throughout only a portion of the external surface, or any combination thereof, without departing from the scope of the present invention. In those circumstances where there is no undrilled bone in the disc space forward of the spinal fusion implant **300** to resist further forward advancement of the implant, surface knurling **320** is preferred as it produces an exceedingly high interference fit with the bone of the vertebrae and resists motion equally in all directions and without the tendency to urge itself forward.

Referring to FIG. 10, an alternative embodiment of the spinal fusion implant of the present invention is shown and is generally referred to by the numeral **400**. The spinal fusion implant **400** has a similar configuration to that of the spinal fusion implant **200**, except that it comprises a partially cylindrical member having arcuate portions **402** and **404** which are arcs of the same circle with portions of its outer wall that are flattened so as to present a first flat side **406**. Alternatively, the implant **400** may have a second flat side that is diametrically opposite to the first flat side **406**. The spinal fusion implant **400** is substantially the same as the spinal fusion implant **200**, except that the openings **428** are positioned on the ratcheting **420** such that the openings **428** are positioned between the bone engaging edges **422** and are not bisected by the bone engaging edges **422**.

Referring to FIG. 11, an alternative embodiment of the spinal fusion implant of the present invention is shown and generally referred to by the numeral **500**. The spinal fusion implant **500** is substantially identical to the spinal fusion implant **400** described above except that in place of ratchetings **420**, it has surface knurling **520**. The surface knurling

520 assists in the retaining of the spinal fusion implant **500** once it is inserted across the disc space between two adjacent vertebrae. It is recognized that the surface knurling **520** of the implant **500** may be combined with any of a number of other surface roughenings such as, but not limited to, ratchetings to assist in retaining the spinal fusion implant **500** across the disc space.

Referring to FIG. 12, an alternative embodiment of the spinal fusion implant of the present invention generally referred to by the numeral **600** is shown. The spinal fusion implant **600** has the same structure as the spinal fusion implant **300** described above but instead of knurling **320** has a different surface roughening. The spinal fusion implant **600** has a surface roughening comprising of a blasted external surface **601** which may be stippled to provide an engagement surface for the vertebrae when inserted across the disc space. The spinal fusion implant has a plurality of openings **628**, a removable cap **630** for accessing an internal chamber.

Referring to FIG. 13, an alternative embodiment of the spinal fusion implant of the present invention generally referred to by the numeral **700** is shown. The spinal fusion implant **700** is similar to spinal fusion implant **400** described above except that it has openings in the form of horizontal slots **728** on the flat side **706** and vertical slots **729** on the cylindrical portion of the spinal fusion implant **700**. The spinal fusion implant **700** has ratchetings **720** for engaging the bone of the vertebrae similar to the ratchetings **220** described above.

It is appreciated that the spinal fusion implants of the present invention may include any and all surface roughening configurations that either increase the surface area or interference fit of the implant and the vertebrae. It is appreciated that the ratchetings described above for the various embodiments of the spinal fusion implants of the present invention may also comprise a knurled or other surface roughenings in combination with the ratchetings to further enhance the retention of the spinal fusion implant across the disc space once inserted.

Referring to FIG. 14, an alternative embodiment of the spinal fusion implant of the present invention is shown and generally referred to by the numeral **800**. The spinal fusion implant **800** is similar in configuration to the spinal fusion implant **100** discussed above. However, instead of an external thread, the spinal fusion implant **800** has a plurality of longitudinal splines **810** along its external surface. The splines **810** are parallel to the central longitudinal axis **L** of the implant **800** in the direction of insertion of the implant **800**. The splines **810** have a sharp edge **812** and a sharpened leading end **814** to facilitate insertion of the spinal fusion implant **800** into the adjacent vertebrae. Located between the splines **812** are a plurality of slots **820** that allow bone growth into the implant and into the internal chamber of the implant **800** during spinal fusion.

Referring to FIG. 15, the spinal fusion implant **800** is shown inserted from the lateral aspect of the spine into a bore created across the disc space **D** and into the adjacent vertebrae V_1 and V_2 along the transverse width of the vertebrae V_1 and V_2 . The spinal fusion implant **800** is pushed into place by linear advancement such that the splines **810** engage a portion of each of the adjacent vertebrae V_1 and V_2 . The splines **810** function to engage the vertebrae V_1 and V_2 and stabilize the spinal fusion implant **800** once implanted. The splines **810** are oriented longitudinally with respect to the spinal fusion implant **800** to prevent any dislodgement of the spinal fusion implant **800**

from between the vertebrae V_1 and V_2 as result of anterior to posterior motion of the spine. It is appreciated that the number of splines **810** and the configuration of the splines **810** can vary depending on the size of the spinal fusion implant **800** being implanted.

Referring to FIG. 16, an alternative embodiment of the spinal fusion implant of the present invention is shown and generally referred to by the numeral **900**. The spinal fusion implant **900** differs from the implants described above in that it is inserted in the disc space **D** between the adjacent vertebrae of the spine and not into a cylindrical bore created across the disc space. Therefore, the spinal fusion implant **900** does not require the removal of any portion of bone from the adjacent vertebrae as the spinal fusion implant **900** fits within the natural disc space between the adjacent vertebrae. However, the removal of at least a portion of the disc material present between the adjacent vertebrae is required for proper insertion.

The spinal fusion implant **900** comprises a rectangular block **901** having a top surface **902** and a bottom surface **904** for engaging the adjacent vertebrae and may be flat or may conform at least in part. The top and bottom surfaces **902** and **904** may comprise any of the surface roughenings described herein for engaging the bone of the adjacent vertebrae to promote firm stability. The spinal fusion implant **900** may be solid or hollow at least in part and have a plurality of openings **906** to allow bone ingrowth. The openings **906** may be present on all surfaces of the implant **900** and may either pass through the entire implant **900**, or may be closed bottom wells for holding fusion promoting materials.

Referring to FIG. 17, the spinal fusion implant **900** is shown implanted from the lateral aspect of the spine in the disc space **D** between two adjacent vertebrae V_1 and V_2 along the transverse width of the adjacent vertebrae V_1 and V_2 . The spinal fusion implant **900** has a height that is substantially equal to the height of the disc space **D**, a length that is greater than one half the transverse width **W** of the vertebrae and a width that approximates the depth of the vertebrae.

In the preferred embodiment, the spinal fusion implant **900** has a height in the range of 8 mm to 16 mm, with the preferred height being 10–12 mm; a width in the range of 24 mm to 32 mm, with the preferred width being 26 mm; and a length in the range of 32 mm to 50 mm, with 42 mm being the preferred length.

Referring to FIG. 18, an alternative embodiment of the spinal fusion implant of the present invention is shown and generally referred to by the numeral **1000**. The spinal fusion implant **1000** is similar to the spinal fusion implant **900**, but has a narrower width such that more than one spinal fusion implant **1000** may be combined in a modular fashion for insertion within the disc space **D** between the adjacent vertebrae.

Referring to FIG. 19, a plurality of spinal fusion implants **1000** are shown combined in a modular fashion inserted in the disc space **D** from the lateral aspect of the spine and along the transverse width of the vertebrae V_1 and V_2 .

Referring to FIG. 20, an alternative embodiment of the spinal fusion implant of the present invention is shown and generally referred to by the numeral **1100**. The spinal fusion implant **1100** is inserted into the disc space between two adjacent vertebrae from the lateral aspect of the spine and along the transverse width of the vertebrae. The implant **1100** is dimensioned to replace the natural disc material present between two adjacent vertebrae. The implant **1100**

has a generally rectangular body with curved sides **1102** and **1104**. The top and bottom surfaces **1106** and **1108** have a plurality of splines **1110** similar in structure and function as the splines **810** described above. As the implant **1100** is inserted in the disc space, the splines **1110** engage the bone of the adjacent vertebrae.

The implant **1100** is shown as being hollow with openings and slots **1114** in the outer surface of the implant **1100** permitting bone ingrowth into the interior of the implant **1100**. However, it is appreciated that the implant **1100** may be solid and may have channels or wells in place of opening **1112** to permit bone ingrowth and incorporation of the implant **1100** into the spinal fusion mass. The interior of the implant **1000** may be accessed through the aperture **1120** which may be closed with a snap fit cover.

While the present invention has been described in detail with regards to the preferred embodiment, it is appreciated that other variations of the present invention may be devised which do not depart from the inventive concept of the present invention.

What is claimed is:

1. A translateral spinal implant for insertion from the lateral aspect of the spine in the disc space between two adjacent vertebrae, said implant having a length that is greater than one half the transverse width of the vertebrae, said length being substantially greater than the depth of the vertebrae, and a height for contacting each of the two adjacent vertebrae.

2. The spinal implant of claim 1 in which said implant has a height that is greater than the disc space and is capable of engaging both of said vertebrae.

3. The spinal implant of claim 1 in which said implant has surface roughenings for engaging said two adjacent vertebrae and for maintaining said implant in place, said surface roughenings being present on at least a portion of the exterior of said implant.

4. The spinal implant of claim 3, in which said surface roughenings include a plurality of ratchetings.

5. The spinal implant of claim 4, in which said ratchetings face one direction.

6. The spinal implant of claim 3, in which said surface roughenings include knurling.

7. The implant of claim 6 in which said implant has a cap on at least one end for removably closing said hollow portion of said Implant.

8. The spinal implant of claim 4 in which said surface roughenings include a plurality of longitudinal splines.

9. The spinal implant of claim 1 having a plurality of openings capable retaining fusion promoting material.

10. The spinal implant of claim 1 in which one end of said implant includes an engagement means for engaging instrumentation for the insertion of said implant.

11. The spinal implant of claim 1 in which said implant comprises a fusion promoting material.

12. The spinal implant of claim 1 in which said implant is at least in part bioabsorbable.

13. The spinal implant of claim 1 in which said implant has an internal chamber and an access opening for accessing said internal chamber.

14. The spinal implant of claim 13 in which said implant has means for closing said access opening.

15. The spinal implant of claim 13, in which said internal chamber is capable of containing fusion promoting material.

16. The spinal implant of claim 13, in which said implant comprises a wall surrounding at least in part said internal chamber.

17. The spinal implant of claim 16, in which said wall has a plurality of openings passing therethrough in communication with said internal chamber.

18. The implant of claim 1 in which said implant includes driving engaging means for engaging a driving instrument for implanting said implant within the disc space between the two adjacent vertebrae.

19. The implant of claim 1 in which said implant is generally rectangular in shape.

20. The implant of claim 1 in which said implant is generally square in shape.

21. The implant of claim 1 which said implant comprises a plurality of modular members, each of said modular members having a length that is greater than one half the transverse width of the vertebrae, said length being substantially greater than the depth of the vertebrae, a height dimensioned to fit in the space created by the removed disc material from between two adjacent vertebrae, and a width less than the depth of the vertebrae.

22. The spinal implant of claim 21 in which said implant has a height that is greater than the disc space and is capable of engaging both of said vertebrae.

23. The spinal implant of claim 1 in which said implant comprises a bone ingrowth material.

24. The implant of claim 1 for use in the lumbar spine in which the length of said implant is in the range of approximately 35 mm to 50 mm.

25. The implant of claim 1 for use in the thoracic spine in which the length of said implant is in the range of approximately 12 mm to 30 mm.

26. The spinal implant of claim 1 in which said implant has a height that is greater than the disc space and is capable of penetrating into each of the two adjacent vertebrae.

27. The spinal implant of claim 26 in which said implant is at least in part cylindrical in shape.

28. The spinal implant of claim 27, in which said implant has an external thread for engaging the vertebrae.

29. The spinal implant of claim 27, in which said implant is hollow.

30. The implant of claim 27, for use in the lumbar spine in which the diameter of said implant is in the range of approximately 22 mm to 30 mm.

31. The implant of claim 27, for use in the thoracic spine in which the diameter of said implant is in the range of approximately 14 mm to 26 mm.

32. The implant of claim 27, for use in the lumbar spine in which said implant has a length in the range of approximately 38 mm to 44 mm and diameter in the range of approximately 24 mm to 30 mm.

33. The implant of claim 27, for use in the thoracic spine in which said implant has a length in the range of approximately 12 mm to 30 mm and diameter in the range of approximately 14 mm to 26 mm.

34. A translateral spinal implant for insertion from the lateral aspect of the spine in the disc space between two adjacent vertebrae, comprising:

a plurality of modular members, each of said modular members having a length that is greater than one half the transverse width of the vertebrae, said length being substantially greater than the depth of the vertebrae, a width less than the depth of the vertebrae, and a height for contacting each of the two adjacent vertebrae, each of said modular members comprising:
upper and lower walls, and side walls, said upper and lower walls forming a support structure including at least a portion of the interior surface of said upper and lower walls for bearing against the end plates of the adjacent vertebrae,

whereby said plurality of modular members are capable of being inserted in between said two adjacent vertebrae.

35. A translateral spinal implant for insertion from the lateral aspect of the spine in the disc space between two adjacent vertebrae, said implant having a length that is greater than one half the transverse width of the vertebrae, said length being substantially greater than the depth of the vertebrae, a height for contacting each of the two adjacent vertebrae, and a width that is at least as great as the height.

36. The spinal implant of claim 35 in which said implant has a height that is greater than the disc space and is capable of engaging both of said vertebrae.

37. The spinal implant of claim 36, in which said implant is at least in part cylindrical in shape.

38. The spinal implant of claim 37, in which said implant has an external thread for engaging the vertebrae.

39. The spinal implant of claim 37, in which said implant is hollow.

40. The spinal implant of claim 35, in which said implant has surface roughenings for engaging said two adjacent vertebrae and for maintaining said implant in place, said surface roughenings being present on at least a portion of the exterior of said implant.

41. The spinal implant of claim 40 in which said surface roughenings include a plurality of ratchetings.

42. The spinal fusion implant of claim 41, in which said ratchetings face one direction.

43. The spinal implant of claim 40, in which said surface roughenings include knurling.

44. The implant of claim 43, in which said implant has a cap on at least one end for removably closing said hollow portion of said Implant.

45. The spinal implant of claim 40, in which said surface roughenings include a plurality of longitudinal splines.

46. The spinal implant of claim 35, having a plurality of openings capable retaining fusion promoting material.

47. The spinal implant of claim 35, in which one end of said implant includes an engagement means for engaging instrumentation for the insertion of said implant.

48. The spinal implant of claim 35, in which said implant comprises a fusion promoting material.

49. The spinal implant of claim 35 in which said implant is at least in part bioabsorbable.

50. The spinal implant of claim 35 in which said implant has an internal chamber and an access opening for accessing said internal chamber.

51. The spinal implant of claim 50, in which said implant has means for closing said access opening.

52. The spinal implant of claim 50 in which said internal chamber is capable of containing fusion promoting material.

53. The spinal implant of claim 50, in which said implant comprises a wall surrounding at least in part said internal chamber.

54. The spinal implant of claim 53, in which said wall has a plurality of openings passing therethrough in communication with said internal chamber.

55. The implant of claim 35, which said implant comprises a plurality of modular members, each of said modular members having a length that is greater than one half the

transverse width of the vertebrae, said length being substantially greater than the depth of the vertebrae, a height to the height of the space created by the removed disc material from between two adjacent vertebrae, and a width substantially less than the depth of the vertebrae.

56. The spinal implant of claim 55 in which said implant has a height that is greater than the disc space.

57. The implant of claim 35 in which said implant is generally rectangular in shape.

58. The implant of claim 35, in which said implant includes driving engaging means for engaging a driving instrument for implanting said implant within the disc space between the two adjacent vertebrae.

59. The spinal implant of claim 35, in which said implant comprises a bone ingrowth material.

60. The implant of claim 35, in which said implant is generally square in shape.

61. A translateral spinal fusion implant for insertion from the lateral aspect of the spine in the disc space between two adjacent vertebrae, said implant having a length that is greater than one half the transverse width of the vertebrae, said length being substantially greater than the depth of the vertebrae, and a height for contacting each of the two adjacent vertebrae; said implant having an outer surface with a plurality of openings passing through said implant, said plurality of openings capable of retaining fusion promoting substances and capable of permitting bone growth in continuity from one of said adjacent vertebrae to the other of said two adjacent vertebrae to permit fusion of said two adjacent vertebrae to occur at least in part through said implants capable of engaging both of said vertebrae.

62. The spinal implant of claim 1 in which said implant is made of an artificial material.

63. The spinal implant of claim 34 in which said implant is made of an artificial material.

64. The spinal implant of claim 35 in which said implant is made of an artificial material.

65. The spinal implant of claim 61 in which said implant is made of an artificial material.

66. The spinal implant of claim 1 in which said implant comprises bone morphogenetic protein.

67. The spinal implant of claim 34 in which said implant comprises bone morphogenetic protein.

68. The spinal implant of claim 35 in which said implant comprises bone morphogenetic protein.

69. The spinal implant of claim 61 in which said implant comprises bone morphogenetic protein.

70. The spinal implant of claim 1 in which said implant comprises a bioactive material.

71. The spinal implant of claim 34 in which said implant comprises a bioactive material.

72. The spinal implant of claim 35 in which said implant comprises a bioactive material.

73. The spinal implant of claim 61 in which said implant comprises a bioactive material.

* * * * *

UNITED STATES PATENT AND TRADEMARK OFFICE
CERTIFICATE OF CORRECTION

PATENT NO. : 5,860,973
DATED : January 19, 1999
INVENTOR(S) : Gary Karlin Michelson

Page 1 of 1

It is certified that error appears in the above-identified patent and that said Letters Patent is hereby corrected as shown below:

Column 12, claim 34,
Line 13, change "interior" to -- exterior --.

Signed and Sealed this

Sixteenth Day of April, 2002

Attest:

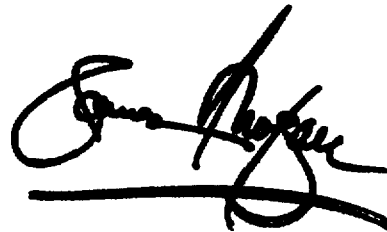

Attesting Officer

JAMES E. ROGAN
Director of the United States Patent and Trademark Office